

STRUCTURAL PRODUCT

Galvanised C & Z Purlins



AJIYA C & Z Purlins

AJIYA C and Z sections are roll formed from high tensile zinc-coated steel. The cold roll forming process used in the manufacture of these sections ensures a high degree of consistency and accuracy in dimensions of the formed sections. Both the C and Z sections are available in 7 sizes of 100, 125, 150, 175, 200, 250 and 300mm with base steel thickness of 1.6, 2.0, 2.5 and 3.0mm. The sections are supplied cut to length and pre-punched. The zinc-coated finish eliminates the need for painting and the erected sections require minimal maintenance throughout the life of the building. The sections also provide efficient light weight, economical roofing and cladding support for framed structures.

MATERIAL SPECIFICATION

GALVANISED

Material Thickness : 1.6mm, 2.0mm, 2.5mm, 3.0mm
 Steel Grade : JIS G3302, Grade G450
 Yield Stress : Min 450MPa
 Coating Mass : Z12 - Z27 (120-275g/m²)

TOLERANCES

The following tolerances apply to both AJIYA C and Z sections

Depth : 1mm
 Width : 2mm
 Length : 3mm
 Hole Centres : 1.5mm
 Thickness : ±0.18mm

AJIYA GALVANISED STEEL C SECTIONS

Dimensions and Properties

The C-sections are normally used as simply supported. Sections of sufficient length may also be used continuously over 2 or more spans to reduce deflection.

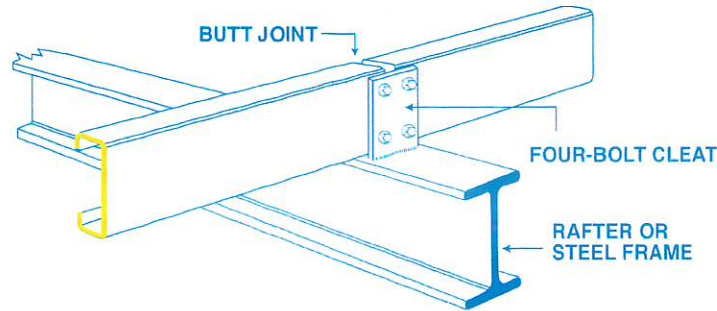
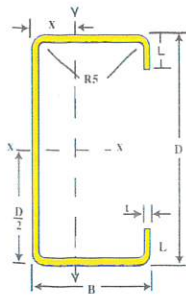

Table 1 - C SECTIONS - DIMENSIONS & PROPERTIES

Purlin Type	Dimension					Area mm ²	Mass Per Unit Length Kg/m	Second Moment of Area		Section Modulus		Radius of Gyration		Torsional Constant	
	D	B	L	t	x			I _x	I _y	Z _x	Z _y	r _x	r _y	J	C _w
	mm	mm	mm	mm	mm			10 ⁶ mm ⁴	10 ⁶ mm ⁴	10 ³ mm ³	10 ³ mm ³	mm	mm	mm ⁴	10 ⁹ mm ⁶
ASC 10016	102	51	14	1.6	17.0	345	2.82	0.57	0.12	11.2	3.6	40.7	18.7	294	0.26
ASC 10020	102	51	14	2.0	16.9	424	3.48	0.69	0.14	13.6	4.2	40.4	18.4	565	0.31
ASC 12516	127	51	15	1.6	15.6	388	3.08	0.96	0.13	15.1	3.8	49.8	18.6	331	0.44
ASC 12520	127	51	15	2.0	15.6	478	3.83	1.17	0.16	18.4	4.5	49.4	18.3	637	0.52
ASC 12525	127	51	15	2.5	15.6	591	4.78	1.43	0.19	22.5	5.4	49.2	18.1	1232	0.61
ASC 15016	152	64	16	1.6	19.3	473	3.85	1.71	0.25	22.6	5.7	60.2	23.2	404	1.16
ASC 15020	152	64	16	2.0	19.3	584	4.79	2.09	0.31	27.5	6.8	59.9	22.9	779	1.38
ASC 15025	152	64	16	2.5	19.3	724	5.97	2.57	0.37	33.8	8.3	59.6	22.7	1508	1.66
ASC 17516	175	74	16	1.6	21.6	539	4.44	2.60	0.38	29.7	7.2	69.4	26.4	460	2.20
ASC 17520	175	74	16	2.0	21.6	670	5.53	3.21	0.46	36.7	8.8	69.2	26.2	893	2.67
ASC 17525	175	74	16	2.5	21.6	831	6.89	3.95	0.56	45.2	10.7	68.9	25.9	1732	3.22
ASC 20016	203	74	16	1.6	20.1	587	4.66	3.70	0.40	36.4	7.4	79.4	26.1	501	3.10
ASC 20020	203	74	16	2.0	20.0	726	5.80	4.53	0.48	44.7	8.9	79.0	25.8	968	3.72
ASC 20025	203	74	16	2.5	20.0	901	7.22	5.59	0.59	55.1	10.9	78.8	25.5	1878	4.49
ASC 20030	203	74	16	3.0	20.1	1074	8.65	6.62	0.69	65.2	12.7	78.5	25.3	3223	5.20
ASC 25020	254	75	20	2.0	19.2	851	6.79	8.01	0.59	63.0	10.5	97.0	26.3	1135	7.29
ASC 25025	254	75	20	2.5	19.1	1054	8.46	9.82	0.71	77.3	12.7	96.5	25.9	2196	8.72
ASC 25030	254	75	20	3.0	19.1	1257	10.13	11.64	0.83	91.7	14.8	96.2	25.7	3772	10.14
ASC 30020	300	95	20	2.0	23.9	1023	8.31	13.69	1.10	91.3	15.5	115.7	32.8	1365	18.63
ASC 30025	300	95	20	2.5	23.8	1269	10.35	16.85	1.34	112.3	18.8	115.2	32.5	2644	22.45
ASC 30030	300	95	20	3.0	23.8	1515	12.39	20.02	1.58	133.4	22.1	114.9	32.2	4546	26.26

Note: 2.5mm & 3.0mm based steel thickness subject to material availability.

AJIYA GALVANISED STEEL Z SECTIONS

Dimensions and Properties

The Z sections are all roll formed with one broad and one narrow flange. These flanges are proportioned so that two sections of the same size, when one is rotated 180°, can be end lapped. These lappings of the Z sections over interior supports of multi-bay buildings produce a structurally continuous line of purlins or girts throughout the length of the building. The dual thickness of material over the interior supports increases the capacity of the sections to resist bending moments as well as improving the load capacity and stiffness of the system.

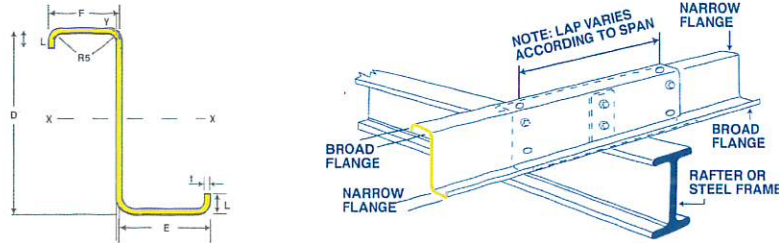

Table 2 – Z SECTIONS – DIMENSIONS & PROPERTIES

Purlin Type	Dimension					Area mm ²	Mass Per Unit Length Kg/m	Second Moment of Area		Section Modulus		Radius of Gyration		Torsional Constant	
	D	E	F	L	t			I _x	I _y	Z _x	Z _y	r _x	r _y	J	C _w
	mm	mm	mm	mm	mm			10 ⁶ mm ⁴	10 ⁶ mm ⁴	10 ³ mm ³	10 ³ mm ³	mm	mm	mm ⁴	10 ⁹ mm ⁶
ASZ 10016	102	53	48	14	1.6	343	2.82	0.57	0.21	10.9	4.1	40.7	24.5	293	0.34
ASZ 10020	102	53	48	14	2.0	419	3.48	0.68	0.24	13.0	4.8	40.3	24.0	558	0.39
ASZ 12516	127	54	48	15	1.6	388	3.08	0.96	0.22	14.8	4.3	49.7	23.8	331	0.59
ASZ 12520	127	54	48	15	2.0	475	3.83	1.15	0.26	17.7	5.0	49.3	23.3	633	0.68
ASZ 12525	127	54	48	15	2.5	596	4.78	1.45	0.32	22.2	6.3	49.3	23.2	1241	0.84
ASZ 15016	152	66	60	15	1.6	467	3.58	1.68	0.39	21.7	6.1	60.1	28.9	398	1.46
ASZ 15020	152	66	60	15	2.0	573	4.79	2.03	0.46	26.2	7.2	59.6	28.3	763	1.71
ASZ 15025	152	66	60	15	2.5	710	5.97	2.50	0.56	32.2	8.8	59.3	28.0	1478	2.05
ASZ 17516	175	76	70	16	1.6	533	4.44	2.55	0.58	28.6	7.9	69.2	33.0	455	2.89
ASZ 17520	175	76	70	16	2.0	663	5.53	3.15	0.71	35.4	9.7	69.0	32.7	883	3.51
ASZ 17525	175	76	70	16	2.5	822	6.89	3.88	0.86	43.6	11.8	68.7	32.4	1713	4.24
ASZ 20016	203	78	72	16	1.6	590	4.66	3.73	0.64	36.1	8.5	79.5	33.0	503	4.43
ASZ 20020	203	78	72	16	2.0	727	5.80	4.54	0.76	44.0	10.1	79.0	32.4	969	5.25
ASZ 20025	203	78	72	16	2.5	902	7.22	5.59	0.93	54.2	12.3	78.7	32.1	1879	6.35
ASZ 20030	203	78	72	16	3.0	1075	8.65	6.62	1.08	64.2	14.4	78.5	31.7	3226	7.36
ASZ 25020	254	79	74	16	2.0	841	6.79	7.91	0.83	61.5	10.7	97.0	31.4	1122	9.39
ASZ 25025	254	79	74	16	2.5	1037	8.46	9.63	0.98	74.9	12.8	96.4	30.8	2161	11.08
ASZ 25030	254	79	74	16	3.0	1237	10.13	11.41	1.14	88.8	15.0	96.0	30.4	3712	12.88
ASZ 30020	300	104	94	23	2.0	1051	8.31	14.23	1.95	93.1	19.4	116.4	43.1	1402	30.24
ASZ 30025	300	104	94	23	2.5	1300	10.35	17.43	2.35	114.0	23.4	115.8	42.5	2707	36.26
ASZ 30030	300	104	94	23	3.0	1552	12.39	20.71	2.76	135.5	27.5	115.5	42.2	4657	42.47

QUICK SELECTION TABLES

The following purlin selection tables for roofing application provide an easy reference for selecting the appropriate purlin sizes.

Table 3 – PURLIN SELECTION TABLE

Span (mm)	Purlin Spacing 1200 mm	Purlin Spacing 1500 mm	Purlin Spacing 1800 mm	Purlin Spacing 2100 mm
4000	10016	10016	10016	12516
5000	10020	12516	12520	12520
6000	12525	15016	15020	15020
	17516	17516	17516	17520
7000	15020	15025	20016	20016
		17520	17520	17525
7500	15025	20016	20016	17525
	17520			
8000	17525	17525	20020	20025
	20016	20016		
9000	20020	20025	20030	25020
			25020	
10000	20030	25020	25025	25025
	25020			
11000	25020	25025	25030	30025
			30025	
11500	25025	30020	30025	30030
		30020	30025	30030
12000	30020	30025	30030	30030

ROOF DECKING AJIYA CL710 - CLIP 'n' LOCKING SYSTEM
(0.55mm TCT) at 5.08kg/m²
50mm the insulation wool (40kg/m³)
One layer aluminium foil
One layer chicken wire mesh.
Live Load = 0.25 kN/m²
Deflection of L/200 is allowed

Table 4 – PURLIN SELECTION TABLE

(M&E Service Load = 0.25 kN/m²)

Span (mm)	Purlin Spacing 1200 mm	Purlin Spacing 1500 mm	Purlin Spacing 1800 mm	Purlin Spacing 2100 mm
5000	12525	15016	15016	15020
6000	15020	15025	20016	17525
	17516	17520	17520	
7000	20016	20020	20025	20025
	17525			
7500	20020	20025	25020	25020
			20030	
8000	20030	25020	25020	25025
		20030		
9000	25020	25025	30020	30025
10000	25030	30020	30025	30025
11000	30020	30025	30030	-
11500	30030	30030	-	-

ROOF DECKING AJIYA CL710 - CLIP 'n' LOCKING SYSTEM
(0.55mm TCT) at 5.08kg/m²
50mm the insulation wool (40kg/m³)
One layer aluminium foil
One layer chicken wire mesh.
Live Load = 0.25 kN/m²
Deflection of L/200 is allowed

Note: - All purlins shall have one bridging at midspan except for those in the shaded area where two bridging are provided at 1/3 and 2/3 spans between supports.

Ajiya Galvanised Steel C and Z sections are normally supplied with standard pre-punched elongated or round holes.

HOLE DETAILS & GAUGE LINES – C & Z SECTIONS

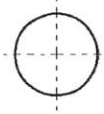
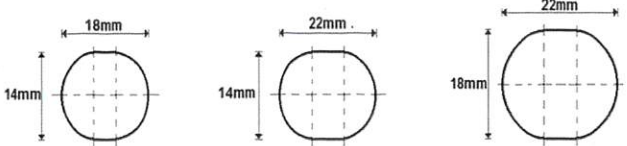
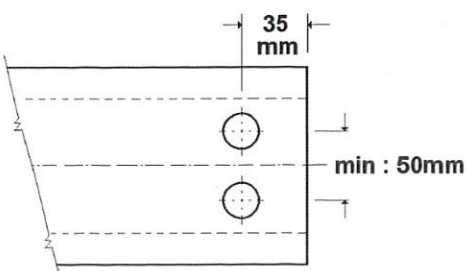
Standard round punched hole	 <p>Size available: $\text{Ø}14\text{mm}$, $\text{Ø}16\text{mm}$, $\text{Ø}18\text{mm}$, $\text{Ø}22\text{mm}$,</p>
Standard elongated punched hole (Hole equally spaced above and below centre line)	
Standard punched hole arrangement	 <p>Applicable to: -100series -125series -150series -175series -200series -250series -300series</p>

HOLDING, CLEATS, FASTENING

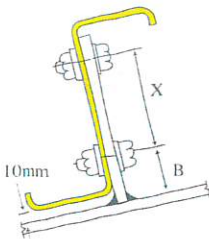

Z Purlins
Lapped

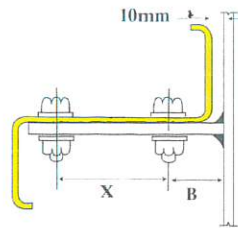

Z Girts
Standard Mode

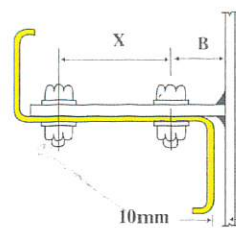

Z Girts
Optional Mode

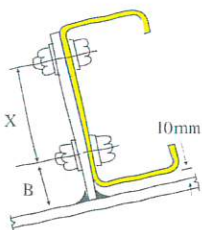

C Girts
Standard Mode

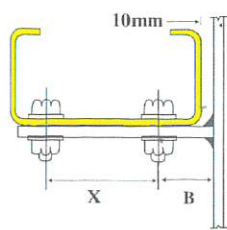

C Purlins

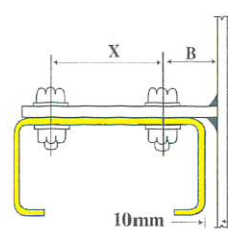

C Girts
Optional Mode

The information and illustration contained herein are for guidance only. Care has been taken to ensure all data and information herein is factual and numerical values are accurate at the time of publication. However, any or all technical specification, information and dimensions are nominal and provisional; they are subjected to change and variations in accordance with market conditions at the date of actual supply. No representation is made or to be implied as to the data and information herein; Asia Roofing Industries Sdn. Bhd. and its subsidiary companies shall not be responsible for any errors in or misrepresentation of the information contained in this brochure or its use. Asia Roofing Industries Sdn. Bhd. and its subsidiary companies reserve the right to alter any or all specifications as deemed fit and necessary without prior notice.

• Colours printed in this brochure are as close as normal printing process would allow and customers are advised to check and verify your chosen colour against an actual sample of the product before purchasing.

www.ajiya.com

Corporate Head Office & Factory
 Lot 153, Kawasan Perindustrian
 Jalan Genuang, 85000 Segamat,
 Johor.
 Tel: +607-943 4211
 Fax: +607-943 1054
 Email: enquiry@ajiya.com

Marketing HQ & Factory
 No. 4, Jalan Sg Pelubung 32/149
 Seksyen 32, 40460 Shah Alam,
 Selangor.
 Tel: +603-5121 0011
 Fax: +603-5121 0111

Southern Marketing Office & Factory
 Lot 7068, Jalan Seelong,
 Kampung Maju Jaya,
 81300 Johor Bahru, Johor.
 Tel: +607-557 3733
 Fax: +607-556 5733

Mentakab Marketing Office & Factory
 No.11, Jalan Industri 3/5,
 Taman Perindustrian Temerloh,
 28400 Mentakab, Pahang.
 Tel: +609-270 1313
 Fax: +609-270 1311

Related Companies
ARI UTARA SDN BHD (273092-U)
 Lot 28, Taman Perindustrian
 Bukit Makmur, 08000 Sungai Petani,
 Kedah.
 Tel: +604-442 2899
 Fax: +604-442 2799

Subsidiary Companies
ARI TIMUR (KB) SDN BHD (714587-K)
 Lot 1306, Kawasan Perindustrian
 Pengkalan Chepa II,
 16100 Kota Bharu, Kelantan.
 Tel: +609-774 5946
 Fax: +609-774 6946

**TO BUILD
 TRUST &
 COMMITMENT
 TOGETHER**